

Synthesis and thermoelectric properties of $\text{Ce}(\text{Ru}_{0.67}\text{Rh}_{0.33})_4\text{Sb}_{12}$.Geoff D. Staneff¹, Paul D. Asimow², Thierry Caillat³¹Department of Materials Science, California Institute of Technology
Pasadena, CA 91125²Division of Geological and Planetary Sciences, California Institute of Technology
Pasadena, CA 91125³Jet Propulsion Laboratory
Pasadena, CA 91109**Abstract**

Exotic filled skutterudite compositions show promise for thermoelectric applications. Current work was undertaken with a nominal composition of $\text{Ce}(\text{Ru}_{0.67}\text{Rh}_{0.33})_4\text{Sb}_{12}$ to experimentally verify its potential as an n-type thermoelectric material. Nominal electroneutrality was expected at 0.89 cerium filling and fully filled materials were expected to be strongly n-type. Filled precursors of the nominal composition were synthesized using straightforward solid state reaction techniques, but standard synthesis routes failed to produce a fully-filled homogenous phase. Instead, the filled thermoelectric $\text{Ce}(\text{Ru}_{0.67}\text{Rh}_{0.33})_4\text{Sb}_{12}$ was synthesized using a combination of solid state reaction of elemental constituents and high pressure hot pressing. A range of pressure-temperature conditions was explored; the upper temperature limit of filled skutterudite in this system decreases with increasing pressure and disappears by 12 GPa. The optimal synthesis was performed in multi-anvil devices at 4-6 GPa pressure and dwell temperatures of 350-700 °C. The result of this work, a $\text{Ce}(\text{Ru}_{0.67}\text{Rh}_{0.33})_4\text{Sb}_{12}$ fully filled skutterudite material, exhibited unexpected p-type conductivity and an electrical resistance of 1.755 mΩ-cm that increased with temperature. Thermal conductivity, Seebeck coefficient, and resistivity were measured on single phase samples. In this paper, we report the details of the synthesis route and measured thermoelectric properties, speculate on the deviation from expected carrier charge balance, and discuss implications for other filled skutterudite systems.

Introduction

In nature, skutterudite is a mineral of composition $(\text{Co},\text{Ni})\text{As}_{3-x}$. Its structure has a number of peculiar electrical and thermal properties that suggest an excellent potential for use in thermoelectric devices. This combination springs from the relatively complicated structure of the simple binary CoAs_3 compound. The skutterudite unit cell is comprised of thirtytwo atoms arranged in a cubic array of corner shared octahedra. These octahedra contain a central cobalt atom surrounded by six shared arsenic atoms. The misalignment of this array creates large void sites between the octahedra and in practice there is significant freedom for chemical substitution on all three of these crystallographic sites. Many transition metals can occupy the cobalt site, either as sole occupants or in solid solution with other transition metals even of disparate valence states. Likewise, the pnictides (P, As, Sb, Bi) can all form skutterudites. The As site can also be doped either p-type with the removal of electrons with a Ge_{Sb} substitution or n-type with the addition of electrons with a Te_{Sb} substitution. Into this significant compositional space one may also introduce substitutions onto the void sites without disrupting the skutterudite

structure. Many workers have introduced rare earth metals into this void in the hopes of reducing the thermal conductivity.

The compositional freedom afforded by the structure coupled with the natural electrical properties of binary skutterudites nominated the system for further study with the goal of improved thermoelectric efficiency. The thermoelectric efficiency of different materials can be judged through a comparison of the dimensionless figure of merit, ZT :

$$ZT = \sigma S^2 T / \lambda$$

Where σ is electrical conductivity, S is the Seebeck coefficient, T is the temperature, and λ is the thermal conductivity. Maximizing the electrical conductivity and Seebeck coefficient while minimizing the thermal conductivity leads to high ZT values and useful thermoelectric behavior. High performance thermoelectric materials typically have ZT values on the order of 1-1.5. While the binary skutterudite has reasonably high electrical properties σ and S , the thermal conductivity is unreasonably high for thermoelectric applications. However, the addition of a void-filling atom, a solid solution on the transition metal or pnictide sites, or any combination of these three substitutions can greatly reduce the thermal conductivity of the skutterudite [1]. Such potential sets skutterudite materials up to serve as excellent thermoelectric materials, if the right combination of thermal and electrical properties can be found in a given skutterudite composition.

Previous work by Fonari and Singh identified the rare-earth filled rhodium-ruthenium skutterudite system as a candidate for thermoelectric device applications on the basis of theoretical calculations [2]. Predictions of low thermal conductivity and a band structure favorable to electrical conduction made this system an appealing direction for further research. The compositions suggested, however, were beyond the reach of standard synthesis techniques. To that end, building upon the initial work of Takizawa [3], a high-pressure synthesis route was developed to yield a single phase, fully filled, quaternary skutterudite composition. Here we present some of the properties of this cerium filled rhodium-ruthenium skutterudite.

Experimental Details

Samples were prepared using a multistage synthesis process. Initial synthesis combined cerium chunk with rhodium and ruthenium powders, which were melted in an induction furnace at 1400 °C. The resulting alloy was combined with antimony shot, placed in a boron nitride crucible and sealed in an evacuated quartz ampoule. The precursors were then held at 650 °C for 48 hours and quenched to room temperature. This product was ground to a particle size no greater than 25 microns.

The next synthesis stage involved a high-pressure, relatively low-temperature, synthesis process. High-pressure synthesis experiments were conducted on a Rockland Research Instruments 1000 ton press. This press is capable of reaching experimental conditions of 2500 °C and 25 GPa, although the sample size decreases with increasing pressure. Experiments were conducted in two internal geometries. Exploratory experiments at 6 GPa and above used an octahedral geometry with an MgO-based solid pressure medium. The successful synthesis and results reported here used a cubic geometry module with a

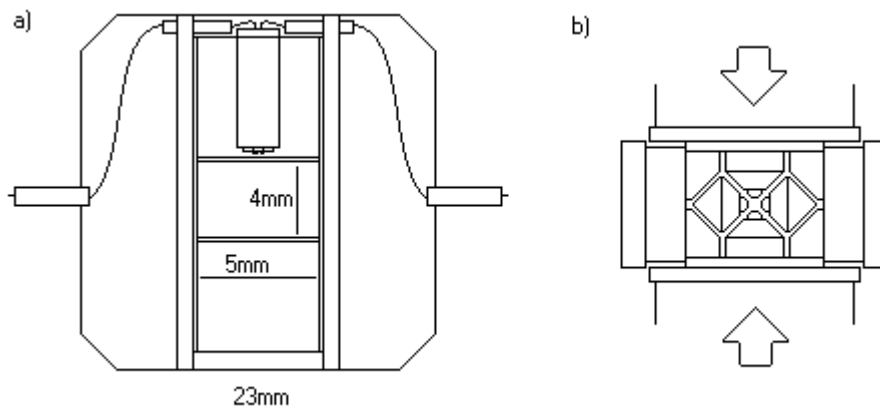

Figure 1. a) Schematic of pressure medium and sample assembly typical of cubic multi-anvil experiments. **b)** Diagram of press action converting uniaxial load into isostatic pressure.

21 mm soft-fired pyrophyllite cube as pressure medium. A 12.7 mm hole is drilled through the cube and a BaCO_3 sleeve inserted as thermal insulation. Inside this, a 7.7 mm outer diameter, 5 mm inner diameter graphite tube makes up the heating element. The sample is sandwiched in the central 4 mm region of the hotspot between graphite disks. Temperature was controlled using an axially mounted type C W/Re thermocouple. Remaining space inside the heater is filled with crushable MgO spacers (Figure 1a). The entire assembly is compressed by six tungsten carbide anvils driven together along the cubic axes by a set of steel guide blocks within a steel containment ring. Deformation of the pressure medium creates a quasi-hydrostatic load within the sample (Figure 1b). Pressure is calibrated as a function of hydraulic load on the press using phase transitions of bismuth at room temperature and, at elevated temperature, the quartz-coesite transition in SiO_2 (3.1 GPa) and the alpha-gamma transition in Fe_2SiO_4 (5 GPa).

Initial survey experiments were conducted over a range of pressure and temperature to find the stability limits of filled skutterudites. Mapping in the cerium-filled cobalt triantimonide system showed, contrary to expectations, that the upper temperature limit above which only diantimonides were found decreases with increasing pressure. (Figure 2). This survey suggested that synthesis conditions of 6 GPa and 600 °C for 24 hours, within the practical range of the largest volume configuration of the octahedral multi-anvil device, would provide successful syntheses of large enough samples for full characterization of thermoelectric properties. However, with these parameters the initial target composition of $\text{Ce}(\text{Ru}_{0.75}\text{Rh}_{0.25})_4\text{Sb}_{12}$ was not achieved. Typically a wide variety of diantimonides were mixed in with a filled skutterudite with a composition $\text{Ce}_{0.8}(\text{Ru}_{0.67}\text{Rh}_{0.33})_4\text{Sb}_{12}$. This composition had been observed in previous synthesis attempts using standard hot pressing techniques (0.1 GPa, 600 °C). Adjusting the nominal composition to reflect this preferred ratio of ruthenium to rhodium and a fortuitous failure in the pressure control system resulted in a single phase $\text{Ce}(\text{Ru}_{0.67}\text{Rh}_{0.33})_4\text{Sb}_{12}$ sample. With our understanding of the P - T relations in these filled skutterudites, the synthesis parameters were adjusted to a pressure of 6 GPa and a

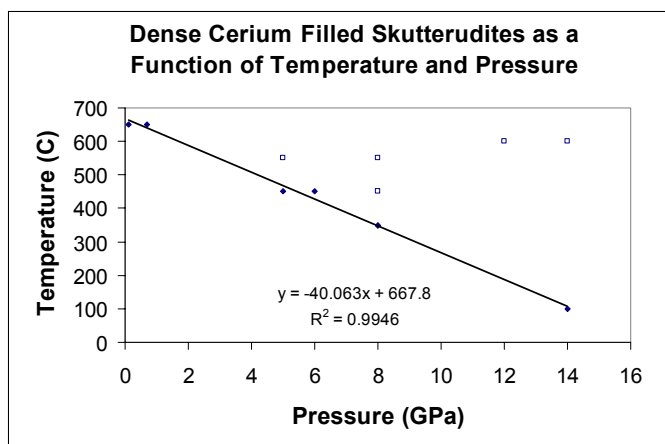

Figure 2. Single phase cerium-filled skutterudite synthesis success (closed diamonds) and failure (open squares) as a function of temperature and pressure. These data show a decreasing synthesis temperature limit with increasing synthesis pressure in $\text{CeCo}_4\text{Sb}_{12}$, which proved useful in setting the synthesis conditions for $\text{Ce}(\text{Ru}_{0.67}\text{Rh}_{0.33})_4\text{Sb}_{12}$.

temperature profile of 600°C for 4 hours and 350°C for 24 hours. Subsequently, conditions were successfully adjusted down to 5 GPa and 4 GPa, allowing the use of the still larger sample volumes of the cubic geometry shown in Figure 1. A pressure of 4 GPa and temperature profile of 700°C for 4 hours followed by 450°C for 24 hours represents the current synthesis parameters.

Once the high-pressure synthesis was completed the skutterudite compositions proved stable to moderately high temperature at standard pressure. The recovered materials were then processed for the last time, grinding them to powder and sintering using standard hot pressing techniques to reconfigure the shape and porosity of the sample to facilitate thermoelectric characterization. Powder X-Ray diffraction and electron microprobe analysis before and after this step confirmed the phase stability of the material through this stage. Electrical properties were characterized with Seebeck coefficient, resistivity, and thermal conductivity measurements using techniques previously reported [4].

Discussion

Thermal conductivity as a function of temperature is shown in Figure 3. Thermal conductivity of $\text{Ce}(\text{Ru}_{0.67}\text{Rh}_{0.33})_4\text{Sb}_{12}$ was half that of the binary skutterudite CoSb_3 . The thermal conductivity is low and stable over a wide range in temperature, with no temperature dependence from 175 to 625°C . However, antimony sublimation was observed above 550°C . This breakdown was severe enough to revert the triantimonide to a wide variety of diantimonides. Once reverted samples were of no further use so great care was exercised to ensure the samples never experienced temperatures above the projected stability limit.

Electrical resistivity and Seebeck coefficient are shown in Figure 4. Again the samples showed signs of sublimation when held at temperatures exceeding 550°C for extended periods of time. The filled rhodium-ruthenium skutterudite showed an electrical

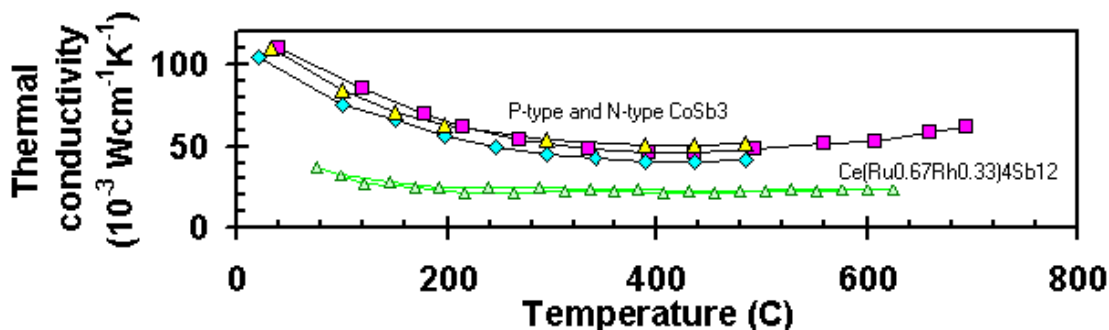

Figure 3. Thermal conductivity as a function of temperature from room temperature to 625 °C showing a much lower value for $\text{Ce}(\text{Ru}_{0.67}\text{Rh}_{0.33})_4\text{Sb}_{12}$ than for the typical binary skutterudite CoSb_3 .

resistance of 1.755 $\text{m}\Omega\text{-cm}$ that increased with temperature. The Seebeck coefficient over the same range was p-type and increasing with temperature. Although the low thermal conductivity confirmed expectations, the electrical properties are surprising for the fully filled $\text{Ce}(\text{Ru}_{0.67}\text{Rh}_{0.33})_4\text{Sb}_{12}$ composition. Strong n-type conductivity was expected from the heavy n-type doping implied by the stoichiometry of the material; the electrical breakpoint was expected at a cerium content of 0.89 while this work achieved a cerium content of 1.00, confirmed by microprobe analysis. The substitutions in this system were as follows:



The Ce filling fraction 0.89, this excess of one-third of an electron per unit cell indicates an addition of 2.27×10^{21} electrons per cm^3 relative to the binary skutterudite. At Ce filling fraction of 1.00, the addition of 2.68×10^{21} electrons per cm^3 should be sufficient to yield unambiguous n-type behavior. The p-type behavior of the fully cerium filled rhodium-ruthenium skutterudite is thus a strong indicator of charge compensation across the transition metal site. The significant number of missing conduction band electrons is

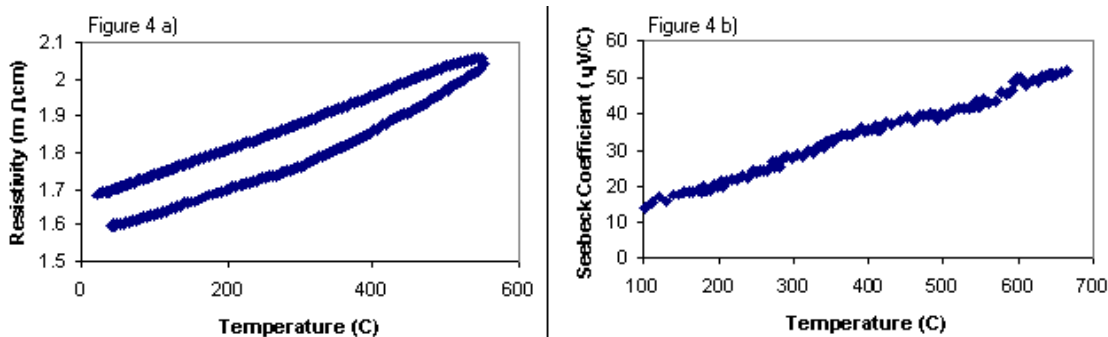

Figure 4. a) Resistivity as a function of temperature from room temperature to 625 °C showing an electrical resistance of 1.755 $\text{m}\Omega\text{-cm}$ that increased with temperature. Note hysteresis between heating and cooling cycles due to partial decomposition above 550 °C. **b)** Seebeck coefficient as a function of temperature from room temperature to 625 °C showing increasing p-type behavior with increasing temperature.

likely related to strong electron localization, which hinders the thermoelectric efficiency of this material.

As noted previously in our work with high cerium filling in cobalt triantimonide [5], the filling ion does not have the expected impact on electrical properties while it does have the expected impact on the thermal properties. Future work will require electrical doping on the transition metal or pnictide site in the skutterudite structure.

Conclusions

We have prepared samples of a cerium-filled rhodium-ruthenium skutterudite material in pursuit of excellent figure of thermoelectric merit ZT due to low thermal conductivity, large n-type Seebeck coefficient and high electrical conductivity. The resulting thermal properties were a significant improvement over binary skutterudites, showing that the combination of cerium filling and doping on the transition metal site is a powerful method of reducing the thermal conductivity in skutterudite materials. However, the resulting electrical properties were unexpected: the observed p-type conduction runs contrary to simple electron counting and indicates a charge compensation mechanism at work. Doping of this system could push the electrical properties back into a range useful for thermoelectric applications; work in this direction is presently underway. The high-pressure synthesis techniques developed working with the cerium-filled rhodium-ruthenium triantimonide and cerium-filled cobalt triantimonide skutterudite systems will facilitate further exploration of alternate skutterudite compositions and we expect to synthesize new skutterudite compositions with further doping on the transition metal, pnictide, or the large void site. The interest in systems with four or more components is driven by the difficulty in arriving at both low thermal conductivity and high electrical conductivity in the same material.

Acknowledgements

This work was made possible through the assistance and guidance of the Thermoelectrics group at the Jet Propulsion Laboratory. The author would also like to thank cerium, ruthenium, rhodium, and antimony; without them this work would not have been possible.

References

1. G.S. Nolas, G.A. Slack, D.T. Morelli, T.M. Tritt, A.C. Ehrlich, "The effect of rare-earth filling on the lattice thermal conductivity of skutterudites," *J. Appl. Phys.* **79** (8), (1996)
2. M. Fornari, D. J. Singh, "Prediction of room-temperature high-thermoelectric performance in n-type $\text{La}(\text{Ru}_{1-x}\text{Rh}_x)_4\text{Sb}_{12}$," *Appl. Phys. Lett.*, Vol. **74**. No. **24**., 3666-3668 (1999).
3. H. Takizawa, K. Miura, M. Ito, T. Suzuki, T. Endo, "Atom insertion into the CoSb_3 skutterudite host lattice under high pressure," *J. Alloy Comp.*, **282**, 79-83, (1999).
4. B. Chen, J.-H. Xu, C. Uher, D. T. Morelli, G. P. Meisner, J.-P. Fleurial, T. Caillat, and A. Borshchevsky, *Phys. Rev. B* **55**, 1476 (1997).
5. G. Staneff, "High Cerium Filling Fraction in CoSb_3 ," 2003 ITS poster session.